

Clarke®

231



Air Compressor

ENGINE DRIVEN

Operating & Maintenance
Instructions



WARNING!

**DO NOT ATTEMPT TO ALTER ENGINE SPEED SETTINGS
DOING SO WILL INVALIDATE YOUR GUARANTEE**

SPECIFICATIONS

	PP15ND	PPH15ND
Part Number	2090980	2091000
Engine Type	HONDA GX200	HONDA GX200
Pump Type	MK103	MK103
Air Receiver size	50 litres	50 litres
Max. output Pressure	100psi	100psi
Air Displacement	15cfm	15cfm
Outlet connectors	1/4" BSP	1/4" BSP
Dimensions (mm)	940 x 410 x 810	1010 x 450 x 810
Weight (kg)	70	74
Sound Power Level**		

** See Declaration of Conformity

NOTE:

Specifications are correct at the time of going to print.
Clarke International reserves the right to change specifications at any time, as it sees fit, in the interests of safety or improvement in design.

Read these safety instructions before using the equipment.

INTRODUCTION

Thank you for purchasing this Clarke portable compressor.

The unit is powered by a Honda engine, a manual for which, is provided separately. Please refer to that manual for all matters relating to the engine, ...starting and stopping procedures, maintenance etc.

GUARANTEE

This product is guaranteed against faults in manufacture for 12 months from purchase date. Please keep your receipt as proof of purchase.

This guarantee is invalid if the product has been abused or tampered with in any way, or not used for the purpose for which it is intended.

The reason for return must be clearly stated.

This guarantee does not affect your statutory rights.

CONTENTS

Page

Specifications	2
Guarantee	3
For your Own Safety	4
Important General Notes	5
General Layout	6
Preparation for Use	7
Starting the Compressor	8
Shutting Down the Compressor	9
Maintenance	10
Parts Lists and Diagrams	11 -13
Troubleshooting	14 -16
Torque values for cylinder head bolts	16
Declaration of Conformity	Back Cover

FOR YOUR SAFETY

WARNING

As with all machinery, there are certain hazards involved with their operation and use. Exercising respect and caution will considerably lessen the risk of personal injury. However, if normal safety precautions are overlooked, or ignored, personal injury to the operator, or damage to property may result.

It is in your own interest to read and pay attention to the following rules:

General Precautions

ALWAYS

- ensure that all individuals using the compressor have read and fully understand the Operating Instructions supplied and are suitably trained
- stop the engine and ensure the pressure is expelled from the air receiver **BEFORE** carrying out any maintenance.
- ensure that there is adequate ventilation when spraying flammable materials e.g. cellulose paint, and keep clear of any possible source of ignition.
- protect yourself. Think carefully about any potential hazards which may be created by using the air compressor and use the appropriate protection. e.g. Goggles will protect your eyes from flying particles. Face masks will protect you against paint spray and/or fumes. Ear defenders will prevent hearing damage caused by loud noise.
- consult paint manufacturers instructions for safety and usage, before spraying
- ensure that the air supply is turned off at the machine outlet and all pressurised air from the machine and other equipment attached to it, is expelled **BEFORE** disconnecting air hoses or other equipment.
- make sure that children and animals are kept well away from the compressor and any equipment attached to it.
- ensure that any equipment or tool used in conjunction with your compressor, has a safety working pressure exceeding that of the machine.

NEVER

- direct a jet of air at people or animals, and NEVER discharge compressed air against the skin. COMPRESSED AIR CAN BE DANGEROUS!
- leave pressure in the receiver overnight, or when transporting.
- adjust, or tamper with the safety valves. The maximum pressure is factory set, and clearly marked on the machine.
- operate in wet or damp conditions. Keep the machine dry at all times. Similarly, a clean atmosphere will ensure efficient operation. Do not use in dusty or otherwise dirty locations.
- touch the machine until it has cooled down...some of the metal parts can become quite hot during operation.
- operate your compressor with any guards removed.

Fire Prevention

ALWAYS

- switch the engine OFF when refuelling.
- refuel away from any source of heat.
- refuel in a well ventilated area.



NEVER

- overfill the tank, fill to the level specified.
- smoke whilst refuelling and avoid smoking or using a naked flame near the compressor.
- start the engine if there is spilled fuel. Any spillage must be wiped clean and the compressor allowed to dry before attempting to start the engine.

Exhaust Gas Precautions

ALWAYS

- ensure there is adequate ventilation when using the compressor.
- position the compressor so that the exhaust is pointed away from people or animals.

NEVER

WARNING:

Exhaust fumes can be fatal

- use the compressor indoors or in an enclosed area. (i.e. in a warehouse, tunnel, well, hold etc.)

IMPORTANT General Notes

- ***NEVER allow anyone, not fully familiar with compressors, to use this equipment.***
- ***DO NOT alter the engine settings....these settings are set at the factory. Should they need recalibration - consult your Clarke dealer***

Fig.1

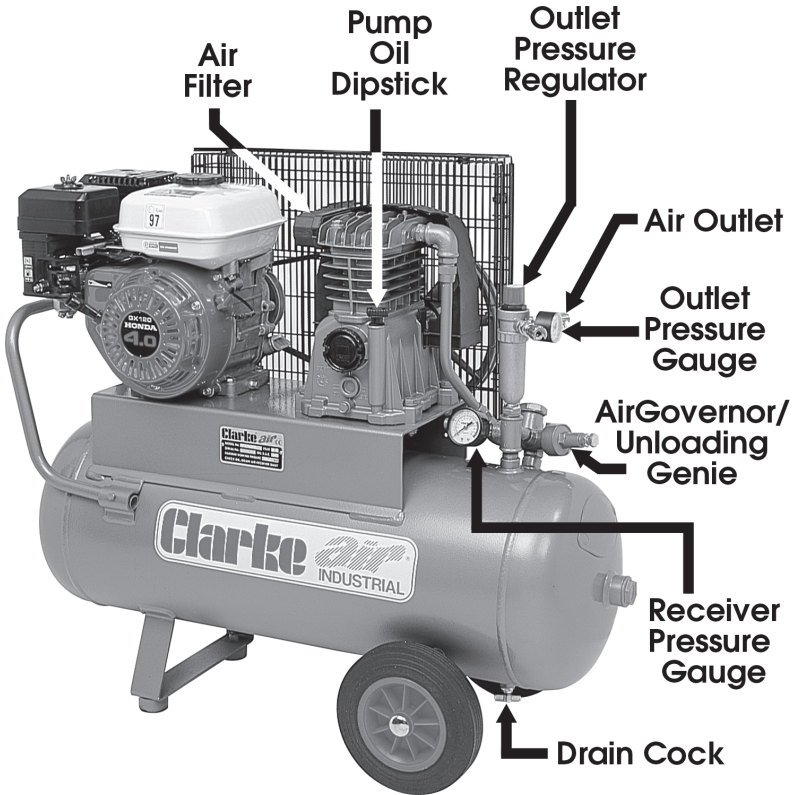

PREPARATION FOR USE

A. Environmental

- Ensure the compressor is sited on a firm level surface.
- Ensure the environment is dry and dust free.
- Ensure there is adequate ventilation for:
 - a) Air intake to compressor pump
 - b) Cooling for compressor pump
 - c) Engine exhaust gases.

B. Engine

Check oil and fuel levels and a visual check of components. Refer to engine service manual.

C. Pump

- Check oil level on the Dipstick - to level marked.

D. Fuelling



Fill with unleaded petrol, according to the instructions within the engine manual.

- Ensure the fuel tap is set to the required position.
- Ensure The fuel hose and connectors are intact, in perfectly serviceable condition and there is no leakage.

Note : *Always use a funnel to fill the fuel tank so as to avoid accidental spillage of fuel. If fuel is spilled it must be removed from the unit and surrounding area, before attempting to start the engine.*

E. Receiver

- Drain off any condensate, by opening the drain cock (see Fig. 1). Remember to close the drain cock when completed.

NOTE: *This should be carried out DAILY when the compressor is in constant use.*

F. Air Hose & Air Tool

- Attach the air hose to the outlet using an appropriate connector.

NOTE: *Quick fit nuts are provided. These may be removed if a 1/4" BSP (male thread) is required.*

- Attach the air tool/spray gun to the air hose...If using snap couplings, use a whip end, available from your Clarke dealer.

STARTING THE COMPRESSOR

Initial Start-up

1. Fully open the receiver drain cock, (located between the wheels).
2. Start the engine, according to the instructions contained in the engine service manual, if this is the first time you use the compressor, allow to run for 10 minutes.
3. After a ten minute period, close the drain cock then ensure both air outlet sliding valves are pushed fully INWARDS to close the outlet.

Pressure will build up in the receiver and eventually the air governor will operate so that the engine runs off load. The pressure registered on the pressure gauge should be 100psi.

4. Slide the outlet taps outwards to allow air to escape from the outlets, and slowly turn the pressure regulator clockwise. Observe the pressure gauge. When the pressure has dropped by approx. 20psi, the Air Governor/Load Genie will operate and the compressor will cut in again. Close the sliding outlet valves and pressure in the air receiver will once again increase
5. Finally, stop the engine and set the pressure regulator to zero pressure (turned fully anticlockwise) and attach the air hose and air tool.
6. Open the sliding valves then set the pressure regulator to full pressure (100psi) and check for air leaks at the tool and connectors.
 - If leaks are apparent, set the regulator to zero pressure (fully anticlockwise), press the trigger of the tool to ensure no air is present in the airline, then rectify the problem before proceeding.
 - If no leaks are evident, Open the bleed valve, start the engine and then close the bleed valve. Set the outlet pressure to the desired value and proceed to use the air tool in accordance with the manufacturers instructions.

Fig.2

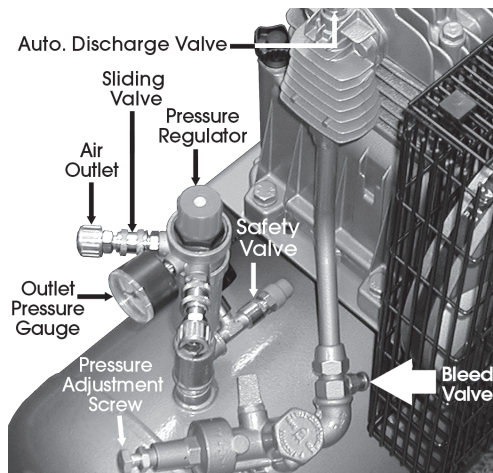

When starting subsequently, start the machine as follows:

1. At the beginning of the day, open the drain cock and allow any condensate to drain completely, then close the drain cock.
2. To ease starting, ensure there is no pressure in the pump outlet manifold by opening the Bleed Valve (See Fig.2).
3. Connect the air hose to one of the outlets and the air tool and set the pressure regulator to zero pressure (turned fully anticlockwise).
4. Start the engine in accordance with the instructions contained in the engine service manual, then close the bleed valve and allow pressure to build up.
5. When the Air Governor/Load Genie has operated and the compressor has gone 'off line', slide the outlet valve outwards fully then adjust the pressure regulator so that the desired pressure is registered on the gauge.
6. Check for air leaks at the tool and connectors, before proceeding.

STOPPING THE COMPRESSOR

At the end of the day, stop the compressor in accordance with the instructions in the engine manual, then open the drain cock.

Close the air outlet by sliding both valves inwards.

Operate the air tool trigger or operating lever etc., to ensure there is no pressure in the air line, then disconnect airline and tool.

WARNING!

DO NOT under any circumstances attempt to remove the air tool or disconnect the air hose until you are satisfied that the pressure has been relieved.

Finally, close the drain cock.

Take care not to touch the engine or pump as they remain hot for some time after use.

MAINTENANCE

DAILY

- Drain Air Receiver of any condensate
- Check engine oil level and top up where necessary. Ensure the dipstick breather hole is not blocked.
- Check pump oil level

WEEKLY

- Clean Pump Air Filter

Unbolt the Pump Air Filter cover and pull away to reveal foam element. If badly contaminated, replace. Remove any loose contaminants if any then replace.

- Clean the engine cooling fins.

6 MONTHLY

Renew pump lubricating oil.

Drain pump by removing the drain screw (Arrowed in Fig.3).

Fig.3

Replace screw and top up until oil is level with the mark on the dipstick, using SAE40 oil available from your Clarke dealer as follows:

Compressor oil - 1 litre: Part No. 3050810

Compressor oil - 5 litre: Part No. 3050802



In addition to the above, check the engine manual for service schedule.

Repairs should only be carried out by a qualified engineer. If problems occur, contact your Clarke dealer.

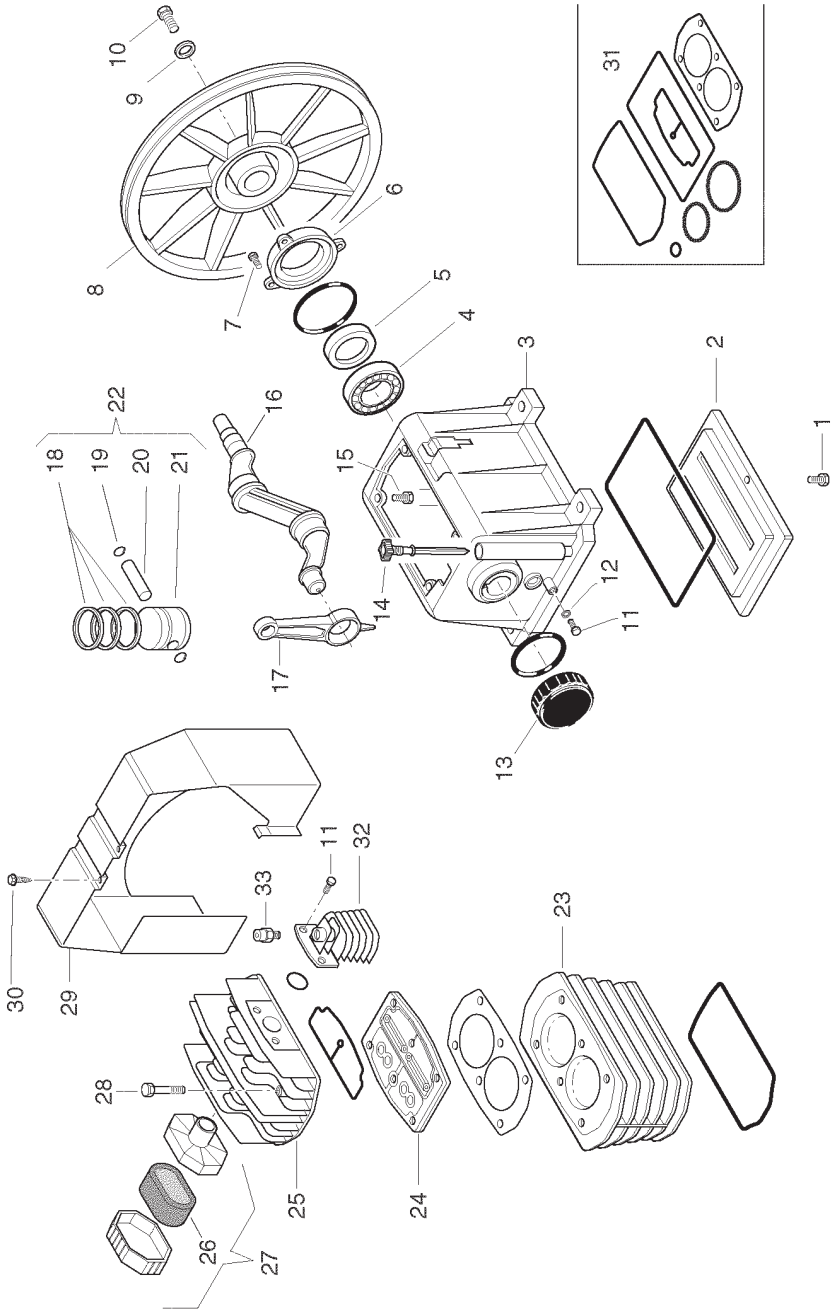

PUMP PARTS



PUMP PARTS

No.	Description	15ND Part No.
1	Screw	014013054
2	Lower Cover	113149015
3	Casing	113167001
4	Bearing	033027000
5	Seal	010053000
6	Front Cover	113149008
7	Screw	014013021
8	Flywheel	013160010
9	Washer	014005001
10	Screw	113160011
11	Screw	014013082
12	Washer	014005025
13	Rear Cover	113149009
14	Oil Dipstick	012036000
15	Screw	014010044
16	Crankshaft	113167003
17	Connecting Rod	113150004
18	Piston Ring Kit	213167001
19	Circlip	015023000
20	Gudgeon Pin	116025006
21	Piston	113164009
22	Complete Piston	413167006
23	Cylinder	113167002
24	Valve Holder Plate	413167005
25	Head	113150022
26	Filter Cartridge	017003000
27	Intake Filter	317001000
28	Screw	014002041
29	Conveyor	113150002
30	Screw	014006121
31	Complete Seal Kit	213167002
32	Manifold	116091024
33	Automatic Discharge Valve	011158000

PARTS LIST

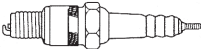
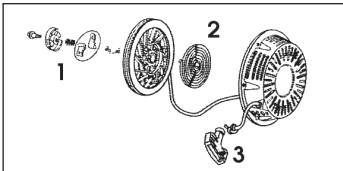
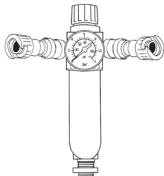
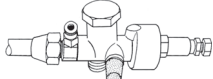
	PP15ND PPH15ND
	HS17210-ZE1-822
	HS17218-ZE1-821
	HS98079-56846
	1. HS28442-ZH8-003 2. HS28442-ZH8-003 3. HS28462-ZH8-003
	5100610
	2100177
50mm Pressure Gauge Safety Valve Complete Drain Cock V-Belt Wheel Wheel Retaining Clip Soft Rubber Foot Pump Complete. Pulley Engine complete Manifold 3-way Air Receiver	2000161 2000192 2000220 2000078 2100289 2100306 2100313 1390085 (MK103) 2100084 800055 (GX200QH) CBM45469000 1999705LP

TROUBLE SHOOTING CHART

IMPORTANT

1. Any remedial work that may be required must be carried out by a qualified engineer.
2. Switch off the engine before removing any parts from the compressor.
3. Drain the Air Receiver before dismantling any part of the compressor unit's pressure system.
4. If your compressor develops a fault do not use until the fault has been rectified.
5. For troubleshooting the engine, refer to the engine manual.

SYMPTOM	PROBABLE CAUSE	REMEDY
Engine difficult to start	Load Genie leaking (compressor unit is on load during start). Load Genie valve blocked, possibly frozen up.	Stop engine and empty air receiver. Clean or replace Load Genie Thaw Load Genie out (Unit must be installed in frost-free place).
Compressor unit constantly 'on load'	Load Genie defective. Load Genie set at a pressure higher than the safety valve's opening pressure. Load Genie leaking.	Have Load Genie serviced or replaced Contact Clarke Service Department Contact Clarke Service Department
Compressor constantly 'on load' and cannot attain the working pressure required.	Suction filter blocked. Leak between compressor block and air receiver leaks in or near air receiver. Valves blocked by dirt, paint, dust or choked up. Inspection cover or drain plug leaking. Pressure gauge defective. Unit too small in relation to air consumption. Compressor worn.	Clean / Change filter. Tighten connection and repair leak. Contact Clarke Service Department Empty air receiver and change seals/plugs. Change pressure gauge. Use a larger capacity compressor Have compressor overhauled or replace it.

<p>Unusual noise from compressor.</p>	<p>Bolts loose. Flywheel loose. Unit installed on an unsuitable base. Bearings, piston rings or cylinder worn. Valve broken.</p>	<p>Tighten bolts - see page 16. Tighten flywheel. Move unit to a more solid base. Contact Clarke Service Department Contact Clarke Service Department</p>
<p>Compressor becomes too hot.</p>	<p>Insufficient ventilation. Oil level too low (check 2 or 3 times after stopping). Fault in valves (machine not stopping). Blown head gasket (machine not stopping). Dirt on cooling fins or suction filter. Unit working at too high a pressure. Not fully unloading Load genie partly blocked. Compressor being overworked and running continuously.</p>	<p>See that sufficient air is supplied to flywheel or fan of compressor and that hot air is properly vented. Fill with oil – see Page 10. Contact Clarke Service Department Contact Clarke Service Department Clean cooling fins and suction filter. Contact Clarke Service Department Contact Clarke Service Department Contact Clarke Service Department Connect to a supplementary compressor or install a larger model.</p>

Compressor unit runs on and off load more frequently than usual.	Large amount of condensation in air receiver. Leaks in system	Drain off condensation Regularly (Every day before use). Locate leaks (by means of soapy water) and repair.
Compressor unit runs 'on load' when no air is being used.	Leaks in system.	Locate leaks (by means of soapy water) and repair.
Compressor's oil consumption rising.	Too much oil in compressor. Leaks around crank case. Working temperature of compressor too high because of insufficient cooling. Cylinder worn. Intake air filter blocked.	Check oil level 2 or 3 minutes after stopping. Contact Clarke Service Department Increase ventilation to air compressor. Contact Clarke Service Department Clean or replace
Oil in the air delivered.	Sump over full. Cylinder worn. Intake air filter blocked.	Reduce oil to correct level. Contact Clarke Service Department Clean / Change air filter.
Oil level rises although no oil has been put in.	Condensation in oil pump.	Compressor over dimensioned.
Condensation at outlet points.	Piping installation incorrect. Compressor taking in air which is too warm.	Consult your local dealer. Obtain better fresh-air supply to compressor.

Torque values for cylinder head bolts

MODEL NUMBER	Torque Vaule (NM)
PP15ND, PPH15ND	20.6 - 21.6

Clarke® INTERNATIONAL

This is an important document and should be retained

DECLARATION OF CONFORMITY

We declare that this product complies with the following standards/directives

- 98/37/EC
- 2000/14/EC ANNEX VI PROCEDURE 1
- 87/404/EEC

Notified Body: A.V. Technology Ltd,

Place: Cheadle Heath, Stockport SK3 0XU

**Tech. File held at: Clarke Int'l Service Centre,
Shrubland Rd., London E10 7RB.**

	Model No.	Measured Sound Power Level	Guaranteed Sound Power Level
<input type="checkbox"/>	PP15ND 4.8Kw	96.0dB _{LWA}	96.5dB _{LWA}
<input type="checkbox"/>	PPH15ND 4.8Kw	96.0dB _{LWA}	96.5dB _{LWA}

Description: **ENGINE DRIVEN AIR COMPRESSOR**

Serial No:

Signed: 
Engineering Manager

Date: 19 March, 2007

Clarke INTERNATIONAL
Hennall Street, Epping, Essex CM16 4LG

Notes

Notes

A SELECTION FROM THE VAST RANGE OF

Clarke®

QUALITY PRODUCTS

AIR COMPRESSORS

From DIY to industrial, Plus air tools, spray guns and accessories.

GENERATORS

Prime duty or emergency standby for business, home and leisure.

POWER WASHERS

Hot and cold, electric and engine driven - we have what you need

WELDERS

Mig, Arc, Tig and Spot. From DIY to auto/industrial.

METALWORKING

Drills, grinders and saws for DIY and professional use.

WOODWORKING

Saws, sanders, lathes, mortisers and dust extraction.

HYDRAULICS

Cranes, body repair kits, transmission jacks for all types of workshop use.

WATER PUMPS

Submersible, electric and engine driven for DIY, agriculture and industry.

POWERTOOLS

Angle grinders, cordless drill sets, saws and sanders..

STARTERS/CHARGERS

All sizes for car and commercial use.

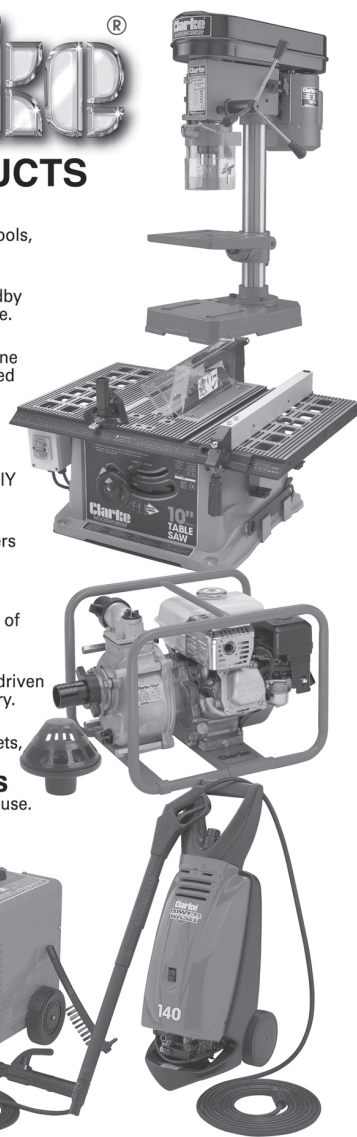
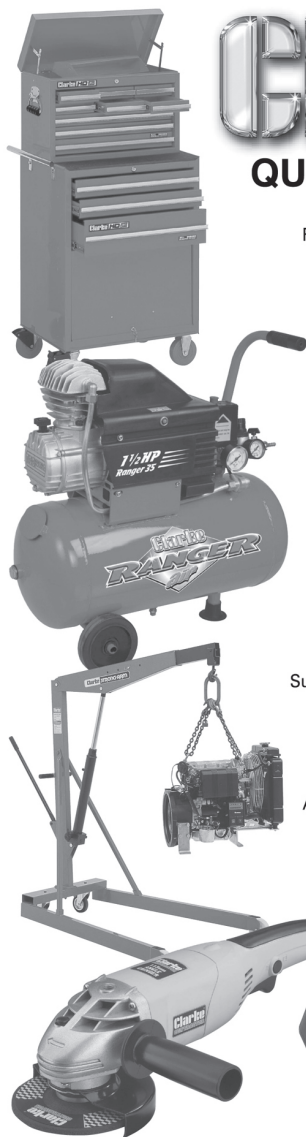

For spare parts and servicing, please contact your nearest dealer, or Clarke International on

020 8988 7400

e-mail: Parts@clarkeinternational.com e-mail: Service@clarkeinternational.com

Clarke INTERNATIONAL
Hemnal Street, Epping, Essex CM16 4LG